

THE BROAD REACH

Volume 13, Number 4, July 2000

A Publication of The Lake Winnepesaukee Sailing Association

Commodore's Corner

by Bob Knowles

Here we are at mid-season. Time just seems to pass so fast, particularly when we wait for those perfect sunshine filled, breezy days. I hope you are catching as many of those perfect days as possible.

Later this month we plan a fun filled day on the water. It's the Treasure Hunt. No entry fee, no registration required. A series of clues will bring you around the lake and ultimately to your chance of finding a treasure. You will need a means of getting at some clues away from your boat. Maybe put a team together, a sailboat and a power boat. Come out Saturday, July 29th and enjoy the fun. Saturday evening, August 12th plan on coming out for an evening's run up and down the lake. The Full Moon Night Sail can be a real thrill. If you have never sailed at night here is a good way to be out there with other boats in a comfortable venue. All boats should be off the water by about 11 PM. Look inside this issue for details on these two fun events.

We were unable to attract any one-design fleets to enter the Winnepesaukee Open One Design (W.O.O.D.) so it was cancelled. It appears that weekends in June are tough dates to get free of personal commitments. Current thought is to not schedule this event next year. Any suggestions for an alternate event to be scheduled in early to mid June?

Much of the last month's attention has gone into the purchase, delivery, and commissioning of our new fleet of Club 420s for the Youth Sailing Program. The excitement is running high with our school staff and among the kids. See the feature article and photos of our new fleet in this issue.

The overall expense for bringing in the 420s will run about \$15000. We are hoping that we will not have to seek a loan to cover the project. The Charitable Donation Program is targeted to provide \$10000 and proceeds from the sale of some of the boats donated to the LWSA the remainder. I'm pleased to

(continued on Page 2)

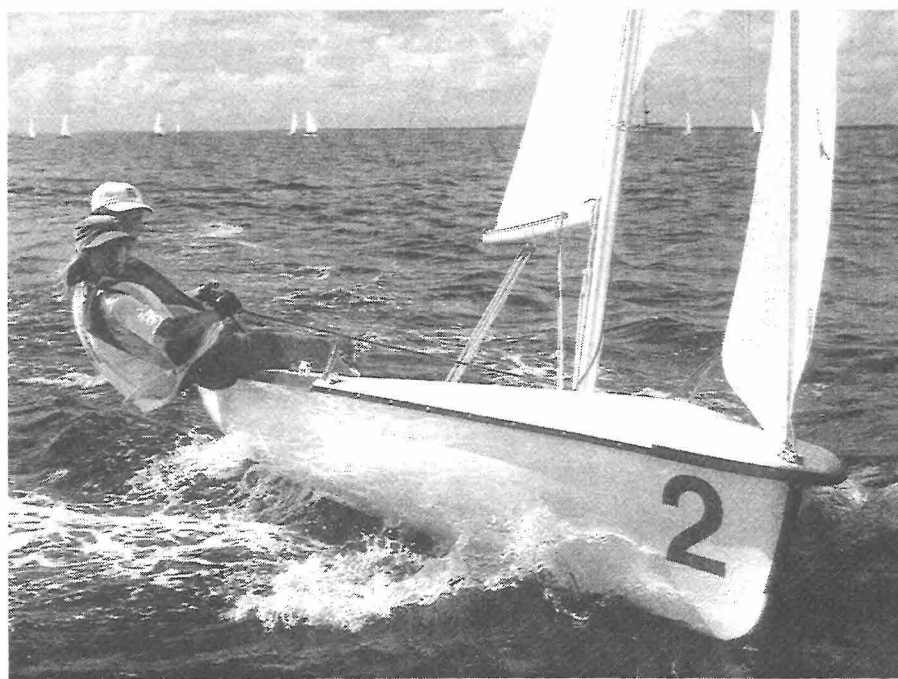

Club 420 Fleet Is a Great Boost for our Youth Sailing Program

(Excerpts from Vanguard 420 Literature)

The Club 420 is the ideal double-handed sailboat for our junior racing program and will provide the starting point for our young sailors who are interested in high performance sailing, college sailing or just having fun. It should also provide a means to couple up adults and youngsters for sailing together, to give adult lessons, and to utilize the boats as part of our long-range plan to get sailing out to the community at large.

As a junior racing boat the Club 420 provides young sailors with an opportunity to experience all levels of one-design sailing. There are more than 1700 boats being actively sailed around the country with another 500 Club 420s in schools and colleges. The U S Sailing/ Rolex Junior Championship, Junior Olympic Nationals, and the Ida Lewis Championships are held in Club 420s.

The Club 420s straightforward fiberglass construction makes repair jobs easy. Heavy duty rigging, a straight mast, external hal-

yards, rail protectors, and bow bumpers make our Club 420s simple to maintain. See the Club 420 specifications and outline drawing in the included figure. It is very simple to add or remove trapeze and spinnaker gear. The boat is easily transportable. Four people can easily lift a Club 420 onto the roof of a van or car. We have purchased lightweight launching carts to transport the boats in and out of the water and around the boat yard. The boats are stored on the dolly carts fully rigged making it very simple for the kids to use.

How Will the Club 420 Meet Our Sailing Program Goals?

Safety: The Club 420 is a self-rescuing double-handed dinghy, which can be righted by two junior sailors without the aid of a motor boat. Positive flotation within tanks and the proper use of personal flotation devices will keep the kids afloat in case of a capsized.

(continued on Page 3)

**Lake Winnepesaukee Sailing Association
& Winnepesaukee Yacht Club
2000 Schedule of Sailing Events**

<u>Date</u>	<u>Sponsor</u>	<u>Event</u>
5/28	LWSA	Michelob Cup Race
6/3		
6/10 & 11	LWSA	W.O.O.D. Regatta (Winnepesaukee Open One Design)
6/17		
6/24	LWSA	Race to Wolfeboro
7/2	WYC	Jimmy Fund Regatta
7/8		
7/15		
7/21	WYC	Single Handed Race
7/22 & 23	WYC	Commodore's Cup Regatta
7/29	LWSA	Treasure Hunt
8/5		
8/12	LWSA	Full Moon Night Sail
8/19		
8/26		
9/1	LWSA	Frying Pan Race (double handed)
9/2	LWSA	Labor Day Regatta
9/9		
9/16 & 17	LWSA	J-Jamboree North
9/23	LWSA	Pearson, Beneteau, Catalina, J-Cruiser Regatta
10/1	WYC	Cold Duck

Regular weekly events:

The following events will be held each week

<u>Day</u>	<u>Sponsor</u>	<u>Event</u>	<u>Start</u>
Wednesday	LWSA	Laser & Opti Racing	1730
Thursday	LWSA	One Design Keelboat Racing	1800
Friday	WYC	PHRF Racing (WYC)	1800

Commodore's Corner (Cont'd from Page 1)

report that we have a pledge from the Winnepesaukee Yacht Club for a substantial donation. Their commitment will bring us a long way toward our goal. Look for the Boats for Sale insert in this issue describing the other boats that LWSA has available for purchase. You or someone you know may be in the market to buy one of these. Help us sell these boats. If you have not sent in a personal, tax deductible contribution as of yet, I encourage you to do so. Be "Counted In" as part of the

support to Youth Sailing. A contribution form is included in this issue for your easy use.

Have you sent in your membership registration for the year yet? Remember that individual membership is now just \$20. Take a moment to fill out and return your membership form and payment for year 2000.

Classified Advertising

Classified ads may be placed up to two weeks prior to publication dates. Cost is \$0.50 per word for members, \$1.00 per word for nonmembers. Make checks payable to LWSA, and remit with ad to LWSA PO Box 7047, Gilford, NH 03247.



LWSA Executive Board

Bob Knowles, Commodore
Brenner Fuller, Vice Commodore
Chuck Moretti, Rear Commodore
Alan Kanegsberg, Treasurer
Donna Garland, Secretary

LWSA Committees

Chuck Moretti, Race Committee
Susan Sparks, Youth Sailing
Nancy Massie, Social
Ed Philpot, One Design
Bob Knowles, *Broad Reach*
Dan Saliga, PHRF
Bob Lemaire, Web Master

The Broad Reach is a publication of the Lake Winnepesaukee Sailing Association (LWSA), PO Box 7047 Gilford, NH 03247. It is circulated to fulfill our non-profit charter which is "...to encourage the sport of sailing." Each issue costs approximately \$250 to produce. If you are receiving these issues as a member, we thank you for your support. If you are not a member, we ask that you consider a tax deductible membership [501(c)(3)] to help us defray publication costs. Thank you.

The Broad Reach is published on a monthly basis during the sailing season. All materials for publication are due by the 7th of the month. Publication or use of any material from *The Broad Reach* is not authorized without written permission. Further, *The Broad Reach* and LWSA disclaim responsibility for typographical errors other than the obligation to print a notice of correction.

Submit materials by mail (3.5" disk preferred) to The Editor, Bob Knowles, 52 Veasey Shore Road, Meredith, NH 03253 or Email: robt@worldpath.net

<u>Size</u>	<u>1 Year</u>	<u>1 Issue</u>
1/2 Page	\$500	\$100
1/3 Page	\$350	\$75
1/6 Page	\$175	\$50

The Broad Reach is circulated to more than four hundred Lakes Region sailors and sailing enthusiasts. Commercial support for The LWSA, a non-profit organization, can be acknowledged with space advertising according to the above schedule. To place an advertisement contact the editor: Bob Knowles at 603-279-8405.

Waxing
Wet Sanding
Compounding
Shrink Wrapping
Snow Plowing
Sanding

Mobile Service
Rug Cleaning
Bottom Washing
Reasonable Rates
Bottom Baint

DIAMOND SHINE

BOAT DETAILING
Come on and Shine
John D. Spooner

PO Box 5195
Weirs Beach, NH 03247

Res: 603-366-7742
Pager: 603-596-4871
Fully Insured

Learning: The Club 420 is an instructional tool, because it can be simply rigged and will introduce young sailors to all the basic sail controls without overwhelming them. The boat is virtually bullet proof when abused by a beginning sailor. The Club 420 is also a responsive sailboat that our junior sailors will enjoy sailing. In the 13 to 16 year range many beginners are turned off of sailing because traditional beginner boats like the Optimist are too small for their body size. Adolescents who have begun to grow will enjoy learning to sail in a boat like the Club 420 because it fits their body size.

Fun and Enjoyable: The Club 420 is a responsive sailboat that our junior sailors will enjoy sailing. In situations that require extra moral support the Club 420 can hold several younger sailors or an instructor and some students. It can also provide intermediate sailors with a greater challenge in the form of trapeze and spinnaker equipment. The Club 420 is a very adaptable addition to our sailing program and will provide new opportunities for junior sailors to enjoy the sport of sailing.

Fleet Racing and Advanced Sailing: The Club 420 will provide our young sailors the chance to become active in one-design sail-

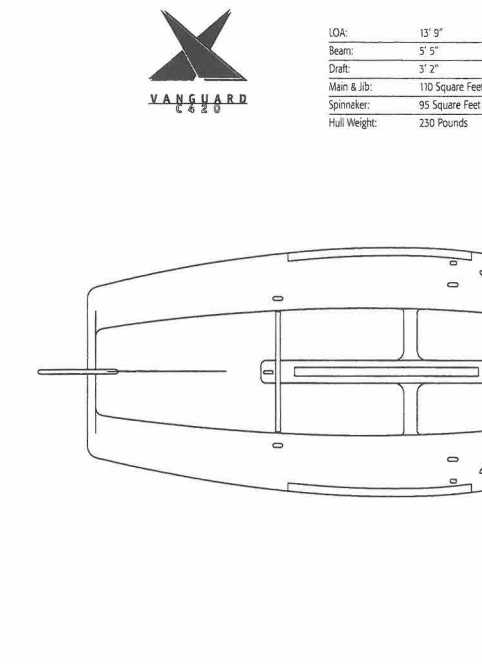

LOA:	13' 9"
Beam:	5' 5"
Draft:	3' 2"
Main & Jib:	110 Square Feet
Spinnaker:	95 Square Feet
Hull Weight:	230 Pounds

boat racing. There is an active regatta schedule in our New England area that sails Club 420s. Most high school and collegiate programs use Club 420s.

Take a look at the photos of the Club 420s in this issue. Better yet, drop by the Smith Cove area and check out our kids enjoying the boats at their classes through August 17th. We are grateful to those who have supported

the purchase of these boats and accessories with your Charitable Gift and graciously ask if you have not donated as of yet, please consider sending in your check today. Additional funds are still required to complete payment and avoid having to secure a loan. We have included a Charitable Donation form for your convenient use. Take the time now and be counted in as part of this year's Youth Sailing Program.

Ice Cream Run to Wolfeboro

This event started out with everyone having the intention to go down to Wolfeboro. Twelve boats sailed past the informal start line off of Belknap Point at (or approximately at) their computed delay time from 12 Noon. Let's hope we listed everyone whom started the run to Wolfeboro.

Ice Cream Run Entrants

Sea Scape
 Berliner Wisse
 Blueberry Pie
 Unwind
 Christina
 Moon Glow
 Catalina 27 Sail #6153
 C'est La Vie
 Haleakala
 Wildflower
 Make n Time
 Gone With The Wind

The light breeze would occasionally build up and push the boats a bit further along but it didn't take more than about 30 minutes to determine that a Wolfeboro arrival was going to be quite late that day, if at all. Most everyone stayed the course with the lead boats having made their way down to the northwestern tip of Diamond Island. Chuck Moretti and Donna Fletcher did a fine job as race committee especially when they made the decision to provide the fleet with ice cream delivered to each boat along with the word that they would go to Wolfeboro some other day. Christina had worked into the lead followed by Gone With The Wind and Haleakala. It was good to see so many boats come out that don't usually race. We hope that this will happen again for our Treasure Hunt and Full Moon Sail events.



J 80 One Design Spring Series Results

The Thursday night One-Design racing has turned out some great competition. For six consecutive Thursday evenings, beginning on May 25th, J80 Fleet #1 held a total of ten races in spite of two abandoned evenings due to the lack of wind. Racing conditions ranged from a gusty 20-knot evening to several floaters. Four boats had at least one first place finish showing the close level of competition that exists within the fleet. In the end, Gostosa, owned by Jeff Kirchhoff and Kevin Hayes, proved to be the boat to beat. One of this year's new additions to the fleet, they consistently finished at the top and easily took top honors for the series.

The J80s have a summer series underway with racing planned each Thursday night through to August 17th.

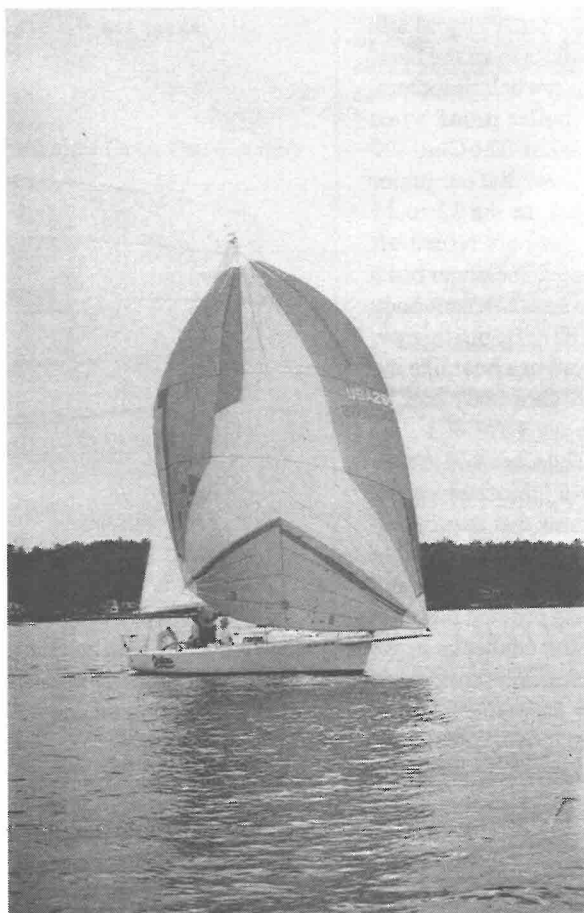

J/80 Gostosa takes first place in Spring One-Design Series

Place	Boat	Skipper	Points
1	Gostosa	Kirchhoff/ Hayes	11.2
2	Pinocchio	Knowles	17.3
3	Blues Power	Lemaire	20
4	Eightball	Bunting	25
5	Schatz	Herte	27.2
6	Christina	Spillane	34
7	Dolce	Sonn	41
8	Excess		
	Bandwidth	Sass	46.7
9	Anagazander	Wilder	53

WYC Jimmy Fund Race Results

Racing A

Yacht	Skipper	R#1	R#2	Points	Place
EXCESS BANDWITH	Sass	1	1	2.00	1
PINOCCHIO	Knowles	2	3	5.00	2
CHRISTINA	Spillane	3	5	8.00	3
GOSTOSA	Kirchhoff	7	2	9.00	4
RUM SQUALL	Mullen	4	6	10.00	5
HOT TUB	Thompson	7	4	11.00	6

Cruising A

Yacht	Skipper	R#1	Points	Place
LEADING INDICATOR	Thibeault	1	1.00	1
AIR EXPRESS	Boucher	3	3.00	2

Cruising B

Racing B

Yacht	Skipper	R#1	R#2	Points	Place
GOOD STUFF	Nickerson	1	3	4.00	1
IMPATIENT	Philpot	2	2	4.00	2
COHERENT	Sibson	6	1	7.00	3
TOTAM	Selig	3	5	8.00	4
MAIL-ORDER BRIDE	Pratt	4	4	8.00	5
FINISHING TOUCH	Egan	5	9	14.00	6
FULL TILT	Bahr	7	9	16.00	7
FORCE 5	Sideris	8	9	17.00	8

Yacht	Skipper	R#1	Points	Place
SERENITY	Richardson	1	1.00	1
ANTICIPATION	Parsons	2	2.00	2
LILY PAD	Saliga	3	3.00	3
WILDFLOWER	Fuller	4	4.00	4
SCOT-FREE	Massie	5	5.00	5
ALEXIS ANNE	Jollimore	7	7.00	6

Mid Season Youth Sailing Program Update

by Meg Heckman, YS Coordinator

A record number of youth sailors are enjoying various aspects of the sport this summer at the LWSA Youth Sailing Camp. With the addition of six Club 420s more kids than ever before have had the opportunity to explore sailing in a variety of ways. During the first half of the summer 38 beginners have received instruction in both the Optimist prams and the new 420s. A total of 73 slots were filled in the first five weeks of the season. We expect to have filled all 126 available slots by the ninth and final week.

In addition to the usual tacking, gybing, and docking drills the kids have participated in dryland activities such as compass navigation, ice cream scavenger hunts, and code flag bingo. One class even made model boats out of peanut butter playdough! After creating fruit leather sails and pretzel stick rigs, the children had to name and describe their sticky creations. The beginners aren't having all the fun, though. By using charts and compasses, the intermediate sailors navigated their fleet to a secret "lagoon" off the Forties, where they rafted up for lunch and swimming.

The acquisition of the 420s has also contributed to a renewed interest in the junior racing team. The Wednesday night one-design races have boasted fleets as large as 12 Lasers and the juniors love mixing it up in the new sloops. On Thursday July 6, four 420s competed in the club Bemis (youth double-handed) run off. Twelve races were sailed in a steady 20 knots of breeze. After several hours of neck-in-neck tacking and covering, Jonathan Ewing and Katie McMenemy emerged as the club champions, a mere one point ahead of the second place boat manned by Stu Johnson and Chris Wilson. The club victory entitled Ewing and McMenemy to travel to the Lake Champlain Yacht Club to compete in the Bemis Western Regionals. Despite their lack of spinnaker experience, the pair managed to squeak out a win in the last race of the series and finished

third over all. Congratulations to Jonathon and Katie and to all the juniors for a job well done.

The next few weeks will prove to be busy ones for both the lesson program and the junior club. The racers will be sailing Lasers, 420s, and Optimists in the WYC Commodore Cup and putting their skills to the test at several

more youth regattas around the region. The young athletes also hope to travel to Kingston, Ontario at the end of August for the CORK Youth Fest, an international youth clinic and regatta. Sailors involved in the lesson program can look forward to an introduction to the J-80 fleet and some possible interclub events with other local sailing programs.



Chuck Moretti and Donna Fletcher delivering ice cream to the becalmed sailors headed to Wolfeboro

Local Knowledge

This location seems to maintain an air of intrigue and mystery to it. How many times have you approached from some two to three miles away, going in a northeasterly direction, and wondered – "Is it there?"

It sometimes has five markers defining its boundaries, other times you might only see four. Other times you might miss one and find yourself aground. So many races seem to prematurely end at this location as the breeze does its customary afternoon dying summer swansong.



Cruisers, Racers Join the *The Treasure Hunt*

No entry fee, no registration required. Just show up! Anyone with a sailboat can participate. This is a fun race. If you are serious about it, loosen up!

WHEN: Saturday, July 29th

SCHEDULE: Sign-up 9:00 AM at Fay's Boat Yard Rec. Room -

Skippers meeting: 10:00 AM

Start: 12:00 (Noon)

INSTRUCTIONS:

THE START: You will receive your first clue at the Skipper's meeting. This will be the clue for you to find the start line. Your time will start when you cross the start line.

THE RACE: At the start line a second clue will be given to you, which will lead you to the third clue, third to the fourth, etc.

THE FINISH: The final clue will lead you to the finish. Your time will be taken there. Shortest overall time wins.

SPECIAL FEATURES: Participants can sail or motor, but one leg of the race must be sailed. Your clue will tell you which leg is to be sailed.

SPECIAL EQUIPMENT: A Sailboat and a Secondary Means of Getting to the clues. You will have to get from your sailboat to the spot of the clue by a different means. This travel distance should be a maximum of 75 to 100 feet.

Ideas of second means of travel could include the following:

Small raft

Young adult to swim

A dinghy

A partner in a motorboat or jet ski

OPTIONS ARE UNLIMITED.... BE CREATIVE.

NOTE: Monitor VHF Channel 72 for assistance and direction.

Need further help? Call Chuck Moretti at 617 908-7111 or e-mail at chuck@crowncost.com.

BOATS FOR SALE

Looking for a boat? Know someone that is? A generous supporter to our organization donated this Capri 22 sailboat to the LWSA. Proceeds from its sale will be applied toward the cost of the Youth Sailing School's new fleet of Club 420s. Help us sell this and the other boats listed here.

1985 Capri 22 Fine 22 foot, fractional rig sloop. Has Catalina main sail and jib, racing package (deep fin keel, tall rig, traveler, backstay, and adjustable sheets/halyards), full electrical system, a forward V-berth, two quarter berths and an aft berth, and a Trail Rite trailer with guide-on. This is a fresh water boat in very good condition. Asking \$6,000.

To see this boat, call Sean Mulligan at Fay's Boat Yard Sales 603 293-0700.

Several of our Youth Sailing School Lasers will be available for purchase at the completion of the school sessions in late August. Call Alan Kanegsberg, 603 225-5635, if interested.

1982 18' Catamaran

We also have an 18-foot catamaran (pedigree unknown) with a full set of sails and trailer. This boat has a lot of fun left in its life. Call Sean Mulligan at Fay's. We are asking \$1,500. Take a look at it and make an offer.

2000 Full Moon Sail Notice of Race

Invitation: The Lake Winnepesaukee Sailing Association is pleased to invite all sailors to the 2000 Full Moon Sail.

Rules: This race will be governed by the 1997-2000 International Yacht Racing Rules and the 2000 Sailing Instructions.

Classes: Two Classes: Spinnaker and Non-Spinnaker.

Entry: No entry fee will be required but all entrants must register at sign-up.

Course: Racing will take place on the main part of Lake Winnepesaukee.

WHEN: Saturday, August 12th

SCHEDULE:

Sign-up 3:00 PM at Fay's Boat Yard Rec. Room

Skippers meeting: 3:30PM

Start: 5:00PM

Finish: 11:00PM

Time Limit: 12 Mid Night Most boats should finish the course by about 11PM. All boats should be off the water by midnight. The race committee boat will be cruising about the course and will conduct radio contact with all registrants at intervals during the race.

Brunch: 11:15 AM at the William Tell on Rt. 11 in Alton

BRUNCH: All LWSA members and their friends are invited to attend whether you sailed or not. The full Brunch menu will be available on a separate check basis. But, since the William Tell is opening early for us they will need an accurate count by August 6th. Call Donna Garland at 603 434-0966 with your reservation count.

AWARDS: 1st, 2nd, and 3rd Place Awards for each Class. Awards ceremony at the Brunch.

NEED HELP? Call Chuck Moretti at 617 908-7111 or e-mail at chuck@crowncost.com.



Count me in!

I want to help introduce more kids to our loved sport of sailing with this tax-deductible contribution to the Youth Sailing Program.

Name _____
 Address _____
 City _____ State _____ Zip _____

- \$50 Crew**
- \$100 First Mate**
- \$250 Captain**
- \$1000 Admiral**
- Other \$ _____**

My donation is to be directed to help with _____

A gift of \$20 or more provides you with all the benefits of LWSA membership for the year. Make your check payable to LWSA and Mail to: LWSA, PO Box 7047, Gilford, NH 03247

2000 LWSA Membership Registration

Name: _____
 Street: _____
 City: _____ State: _____ Zip: _____



Home Phone: _____ Work Phone: _____ Lake Phone: _____

E-Mail Address: _____

Boat Make and Length: _____ Boat Name: _____

US Sailing Association



Please process my USSA Membership for 2000 at the individual rate of \$35, (instead of the regular rate of \$40). I understand that as a member of USSA that I will receive a discount of \$5.00 or 10% of each racing registration fee for having race insurance through USSA. USSA Membership includes a Rule Book, a subscription to *Sailing World* or *Cruising World* magazine and all other membership benefits.

Visit www.ussailing.org for details



Sign me up for a one year BoatUS membership at the special LWSA rate of just \$9.50 (a savings of 50% off the regular rate of \$19). Member benefits include a subscription to BoatUS Magazine, a copy of the 700+ page BoatUS Discount Equipment Catalog, On-the-Water Towing, the availability of low cost boat insurance, and much more. Visit www.boatus.com for details.

Please rush my BoatUS Membership Application at the special LWSA rate. I am a _____ New _____ Renewing BoatUS member

I/we are enclosing the following:

- \$ _____ for LWSA Membership Family \$40 - Individual \$20
- \$ _____ for LWSA Junior Dues (Wed Night Racing) 18 & under - \$10
- \$ _____ for US Sailing Membership (LWSA Members only) Individual \$35 - Youth \$10

\$ _____ **TOTAL ENCLOSED**

Signed: _____ Date: _____

Mail to: Lake Winnepesaukee Sailing Association, PO Box 7047, Gilford, NH 03247

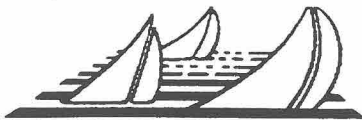

LAKE WINNIPESAUKEE

SAILING ASSOCIATION

P.O. Box 7047
Gilford, NH 03247-7047

July 2000

Postmaster: RETURN SERVICE REQUESTED

Treasure Hunt
Saturday, July 29th

Full Moon Sail
August 12th

Labor Day Regatta
September 2nd